



RWANDA CIVIL AVIATION REGULATION

PART 17: MASS & BALANCE & PERFORMANCE

Consolidated to include Special Regulations issued since last amendment of Ministerial Order N°01/CAB.M/019 OF 06/02/2019 Establishing Civil Aviation Regulations.

Part 17

Mass & Balance & Performance

SUBPART A: GENERAL	3
17.001 CITATION & APPLICABILITY	3
17.003 SUMMARY OF AMENDMENTS AND REVISION HIGHLIGHTS	3
17.005. DEFINITIONS: GENERAL	3
17.010. ACRONYMS & ABBREVIATIONS	3
17.015 MINIMUM REQUIREMENTS	4
SUBPART B: APPLICABLE CODE OF PERFORMANCE	5
17.020 APPLICABILITY	5
17.025 APPROVAL OF CODE OF PERFORMANCE	5
17.030 ACCEPTABLE CODES OF PERFORMANCE	5
17.035 CONSIDERATION OF OTHER CODES OF PERFORMANCE	5
17.037 EXCEPTIONS TO ADOPTED INTERNATIONAL PERFORMANCE STANDARDS	5
SUBPART C: MASS & BALANCE	6
17.040 APPLICABILITY	6
17.045 SUPERVISION OF LOADING	6
17.050 APPROVED METHOD REQUIRED	6
17.060 LAST MINUTE CHANGES	6
17.065 DETERMINATION OF AIRCRAFT EMPTY OPERATING WEIGHT	6
17.070 DETERMINATION OF ACTUAL PASSENGER WEIGHTS	6
17.075 DETERMINATION OF AVERAGE PASSENGER WEIGHTS	7
SUBPART D: COMPUTATIONS OF APPLICABLE WEIGHTS & PERFORMANCE	8
17.080 APPLICABILITY	8
17.085 SOURCE OF PERFORMANCE DATA	8
17.090 OBSTACLE DATA	8
17.095 AIRCRAFT PERFORMANCE CALCULATIONS	8
17.100. MASS LIMITATIONS	9
SUBPART E: AEROPLANE PERFORMANCE & OPERATING LIMITATIONS	10
17.105 APPLICABILITY	10
Subdivision I: Restricted Performance Aero planes	10
17.110. SINGLE ENGINE AERO PLANES	10
17.115. RESTRICTED PERFORMANCE MULTI-ENGINE AERO PLANES	10
Subdivision II: Large or Turbine-Engined Aero planes	10
17.120. TAKEOFF & CLIMB PHASE	10
17.125. ENROUTE PHASE: ALL ENGINES OPERATING	11
17.130. ENROUTE PHASE: ONE ENGINE INOPERATIVE	11
17.135. ENROUTE PHASE: TWO ENGINES INOPERATIVE	12
17.140. APPROACH & LANDING PHASE	12
SUBPART F: HELICOPTER PERFORMANCE & OPERATING LIMITATIONS	14
17.145. APPLICABILITY	14
Subdivision I: Helicopter-General	14
17.150. PERFORMANCE REQUIREMENTS BASED ON PASSENGER CONFIGURATION	14
17.155. ACCOUNTABILITY FOR WIND	14
17.160. OBSTACLE ACCOUNTABILITY AREA	14

Civil Aviation Regulations

17.165. FATO OPERATING AREA CONSIDERATIONS	15
Subdivision II: Operations in Performance Class 1	15
17.170. DEFINITIONS.....	15
17.175. TAKEOFF & INITIAL CLIMB PHASE: PERFORMANCE CLASS 1	16
17.180. TAKEOFF FLIGHT PATH: PERFORMANCE CLASS 1	16
17.185. ENROUTE PHASE: PERFORMANCE CLASS 1: PERFORMANCE CLASS 1.....	17
117.190. ENROUTE PHASE: TWO ENGINES INOPERATIVE: PERFORMANCE CLASS 1.....	17
17.195. APPROACH & LANDING PHASE: PERFORMANCE CLASS 1.....	17
Subdivision III: Operations in Performance Class 2	18
17.200. TAKEOFF & CLIMB PHASE: PERFORMANCE CLASS 2	18
17.205. ENROUTE PHASE: PERFORMANCE CLASS 2.....	18
17.210. ENROUTE PHASE: TWO ENGINES INOPERATIVE: PERFORMANCE CLASS 2.....	18
17.215. APPROACH & LANDING PHASE: PERFORMANCE CLASS 2.....	18
Subdivision IV: Operations in Performance Class 3.....	19
17.220. GENERAL RESTRICTION: PERFORMANCE CLASS 3.....	19
17.225. TAKEOFF & CLIMB PHASE: OPERATIONS IN PERFORMANCE CLASS 3.....	19
17.230. ENROUTE PHASE: OPERATIONS IN PERFORMANCE CLASS 3	19
17.235. APPROACH & LANDING PHASE: OPERATIONS IN PERFORMANCE CLASS 3	19
APPENDICES	20
APPENDIX 1 TO 17.003.- SUMMARY OF AMENDMENTS AND REVISION HIGHLIGHTS	20
APPENDIX 1 TO 17.195: SURFACE LEVEL TAKEOFF: PERFORMANCE CLASS 1	21
APPENDIX 2 TO 17.195: ALTERNATIVE SURFACE TAKEOFF: PERFORMANCE CLASS 1.....	22
APPENDIX 3 TO 17.195: ELEVATED TAKEOFF	23
APPENDIX 1 TO 17.215: SURFACE LEVEL LANDING: PERFORMANCE CLASS 1.....	24
APPENDIX 2 TO 17.215: ELEVATED LANDING: PERFORMANCE CLASS 1	25
APPENDIX 1 TO 17.220: SURFACE LEVEL TAKEOFF: PERFORMANCE CLASS 2	26
APPENDIX 2 TO 17.220: ELEVATED TAKEOFF: PERFORMANCE CLASS 2.....	27
APPENDIX 1 TO 17.235: SURFACE LEVEL LANDING: PERFORMANCE CLASS 2.....	28
APPENDIX 2 TO 17.235: ELEVATED LANDING: PERFORMANCE CLASS 2	29

The Remainder of This Page Intentionally Left Blank

SUBPART A: GENERAL

17.001 CITATION & APPLICABILITY

- (a) These Regulations may be cited as Civil Aviation (Mass, Balance and Performance) Regulations.
- (b) This Part prescribes mass and balance and aircraft performance and operating limitations in addition to those in Part 10.
- (c) These requirements of this Part apply to aircraft used in—
 - (1) Commercial air transport operations; and
 - (2) General aviation operations, by—
 - (i) Turbojet airplanes; and
 - (ii) Large airplanes.
- (d) This Part is applicable to the persons and entities that operate the aircraft and the persons performing duties on their behalf.
- (e) Civil Aviation Technical Standards published by the Authority shall also be applicable to the mass, balance and performance of aircraft operations.

17.003 SUMMARY OF AMENDMENTS AND REVISION HIGHLIGHTS

- (a) The summary of amendments and Revision Highlights to this part are contained in Appendix 1 to 17.003.

New: Internal: Special Regulation RSR/01/2020: Effective 15 November 2020

17.005. DEFINITIONS: GENERAL

- (a) All definitions applicable to this Part are contained in Part 1 (Appendix 1 to 1.015).

17.010. ACRONYMS & ABBREVIATIONS

- (a) The following acronyms are used in this Part and shall apply to both aero planes and helicopters—
 - C.G.** = Center of Gravity
 - ft** = feet
 - m** = meters
 - MEA** = Minimum Enroute Altitude
 - MSL** = Mean Sea Level
 - PIC** = Pilot In Command
 - sm** = Statute Miles
 - V_y** = Best rate of climb speed.
- (b) The following acronyms and abbreviations apply to the airplanes performance requirements of this Part—
 - ASDA** = Accelerate-stop distance available
 - AFM** = Aeroplane Flight Manual.
 - LDA** = Landing distance available
 - V₁** = Takeoff decision speed
 - V_{mo}** = Maximum operating speed
 - V_{so}** = Stalling speed or the minimum steady flight speed in the landing configuration
- (c) The following acronyms and abbreviations apply to the helicopter performance requirements of this Part—
 - D** = Maximum dimension of helicopter

Civil Aviation Regulations

DPBL = Defined point before landing
DPATO = Defined point after take-off
DR = Distance travelled (helicopter)
FATO = Final approach and take-off area
HFM = Helicopter flight manual
HOGUE OEI = Hover Out of Ground Effect with One Engine Inoperative
LDP = Landing decision point
LDAH = Landing distance available (helicopter)
LDRH = Landing distance required (helicopter)
R = Rotor radius of helicopter
RFM = Rotorcraft Flight Manual
RTODR – Rejected take-off distance required (helicopter)
TDP = Take-off decision point
TLOF = Touchdown and lift-off area
TODAH = Take-off distance available (helicopter)
TODRH = Take-off distance required (helicopter)
V_{Toss} = Take-off safety speed

17.015 MINIMUM REQUIREMENTS

- (a) Each person operating an aircraft subject to the applicability of this Part shall comply with the minimum performance approved or accepted by the Authority under the provisions of this Part.
- (b) The Authority may authorize deviations from the requirements of this Part if special circumstances make a literal observance of a requirement unnecessary for safety.
- (c) Where full compliance with the requirements of the Part cannot be shown due to specific design characteristics (e.g., seaplanes, airships, or supersonic aircraft), the operator shall apply approved performance standards that ensure a level of safety not less restrictive than those of relevant requirements of this Part that are acceptable to the Authority.

The Remainder of This Page Intentionally Left Blank

SUBPART B: APPLICABLE CODE OF PERFORMANCE

17.020 APPLICABILITY

- (a) This Subpart provides the requirements applicable to the code of performance that shall be used by those operators subject to this Part.

17.025 APPROVAL OF CODE OF PERFORMANCE

- (b) For aircraft of Rwanda registry, the operators of such aircraft must comply with the comprehensive and detailed code of performance approved for their aircraft during the process of certification by the Authority.
- (c) For aircraft of other States of Registry to be operated under a Rwanda registry, the operators of such aircraft must comply with the comprehensive and detailed code of performance accepted for their aircraft during the process of certification by the Authority, provided that such codes are found to meet the minimum requirements of this Part.

17.030 ACCEPTABLE CODES OF PERFORMANCE

- (a) The following comprehensive and detailed codes of performance will be available to and may be required by the Authority for commercial air transport operations of the category and class of aircraft—
 - (1) United States Federal Aviation Administration;
 - (2) European Joint Aviation Authorities;
 - (3) Canadian Ministry of Transport;
 - (4) National Civil Aviation Agency of Brazil.; and
 - (5) Any other code of performance accepted by the Authority following the provisions of Regulation 17.035.

17.035 CONSIDERATION OF OTHER CODES OF PERFORMANCE

- (a) To be eligible for approval or acceptance by the Authority, the comprehensive and detailed code of performance issued by an ICAO Contracting State for commercial air transport may be considered provided—
 - (1) The Code is in conformance with the applicable Standards of ICAO Annex 6 and 8;
 - (2) The use of this Code will result in performance that meets the minimum requirements contained in this Part;
 - (3) This Code is in English or certified translation to English;
 - (4) A copy of this Code is provided with the application for including the aircraft on Rwanda registry; and
 - (5) There is a satisfactory method of updating the Authority's copy of this Code throughout the period of time the aircraft is registered in Rwanda.

17.037 EXCEPTIONS TO ADOPTED INTERNATIONAL PERFORMANCE STANDARDS

- (a) Where new or revised ICAO Annex 8 Standards for required performance affecting a specific aircraft type are adopted, the Authority may grant an exception to allow continued operations after the effective date while the aircraft is modified to meet the new Standard.
- (b) The aircraft owner or operator must petition the Authority for this exception, citing the basis and propose the plan for modification to meet the new Standard as soon as practicable.

Civil Aviation Regulations

SUBPART C: MASS & BALANCE

17.040 APPLICABILITY

- (a) This Subpart is applicable to the general requirements for the supervision and procedures that are applicable to mass and balance.

17.045 SUPERVISION OF LOADING

- (a) Each AOC holder shall designate in writing the person(s) that is to—
 - (1) Supervise the proper loading of the aircraft;
 - (2) Make the computation of the load manifest for aircraft loading and centre of gravity; and
 - (3) Determine that the aircraft will be capable of meeting the applicable performance requirements.
- (b) This person(s) will be trained to competence for these tasks on each aircraft type and variant before being allowed to sign the load manifest.
- (c) The person(s) supervising the loading and computing the aircraft load, centre of gravity and performance shall be provided the relevant current weights and aircraft limitations that will affect the performance of that aircraft.

17.050 APPROVED METHOD REQUIRED

- (a) No person shall compute the load manifest using any method, policy or information other than specifically approved by the Authority for the—
 - (1) Aircraft type;
 - (2) Supplemental loading documents;
 - (3) Seasonal issues,
 - (4) Non-standard passengers; and
 - (5) Type of operation to be conducted.

17.055 SIGNATURE REQUIRED.

- (a) The person preparing the load manifest shall be named on the document.
- (b) The person supervising the loading of the aircraft shall confirm by signature that the load and its distribution and in accordance with the load manifest.

17.060 LAST MINUTE CHANGES

- (a) Last minute changes to aircraft loading will be provided to the PIC and the person(s) responsible for computation of the aircraft loading and C.G.
- (b) Unless there is an approved methodology for considering last minute changes to passenger or cargo weights, the person responsible for the computation will recompute all factors.
- (c) The effect of the last minute changes will be provided to the PIC and the person(s) responsible for the computation of the aircraft loading and C.G.
- (d) This information shall be noted on the load manifest that is retained at the airport of departure.

17.065 DETERMINATION OF AIRCRAFT EMPTY OPERATING WEIGHT

- (a) The aircraft's empty or dry operating weight must be determined through a weighing of the aircraft 2 years after the date of manufacture and thereafter at intervals not exceeding 5 years and at such times as the Authority may require.
- (b) This information shall be provided to the person who is responsible for the computation of the mass and balance and centre of gravity.

17.070 DETERMINATION OF ACTUAL PASSENGER WEIGHTS

- (a) When making the determination of actual weights, the passengers' personal belongings and carry-on baggage must be included.
- (b) The weighing of the passengers and their items shall be conducted immediately prior to boarding

and at an adjacent location.

17.075 DETERMINATION OF AVERAGE PASSENGER WEIGHTS

- (a) No person may use average passenger weights in the computation of aircraft loading and C.G., unless there has been a determination of the relationship between the actual weights being carried and the selected average weights to determine their validity.
- (b) The method for the determination of the relationships shall be determined through the method prescribed by the Authority.

The Remainder of This Page Intentionally Left Blank

SUBPART D: COMPUTATIONS OF APPLICABLE WEIGHTS & PERFORMANCE

17.080 APPLICABILITY

- (a) This Subpart is applicable to the general requirements applicable to computations of weight, balance and operating performance for specific flights.

17.085 SOURCE OF PERFORMANCE DATA

- (a) An operator shall ensure that the approved performance data contained in the approved flight manual is used to determine compliance with the requirements of this Part supplemented as necessary with other data acceptable to the Authority.

17.090 OBSTACLE DATA

- (a) The operator shall use available obstacle data applicable to the take-off, initial climb, approach and landing phases for the performance computations detailed in this Part.
- (b) The operator shall use obstacle data from a source acceptable to the Authority for takeoff and landings and maneuvering for these procedures for operations of—
 - (1) Large aero planes;
 - (2) Turbine-powered aero planes; and
 - (3) Helicopters in congested hostile environments.
- (c) The computations shall take into account the factors which may affect charting accuracy when using the obstacle data.

17.095 AIRCRAFT PERFORMANCE CALCULATIONS

- (a) No person may commence a flight without ensuring that the applicable operating and performance limitations required for this Part can be accurately computed based on the AFM, RFM, or other data source approved by the Authority.
- (b) Each person calculating performance and operating limitations for aircraft shall ensure that performance data used to determine compliance with this Part can, during any phase of flight, accurately account for—
 - (1) Any reasonably expected adverse operating conditions that may affect aircraft performance;
 - (2) One engine failure for aircraft having two engines, if applicable; and
 - (3) Two engine failure for aircraft having three or more engines, if applicable.
- (c) When calculating the performance and limitation requirements, each person performing the calculation shall, for all engines operating and for inoperative engines, accurately account for—
 - (1) In all phases of flight—
 - (i) The mass of the aircraft;
 - (ii) Operating procedures;
 - (iii) The effect of fuel and oil consumption on aircraft weight;
 - (iv) The effect of fuel consumption on fuel reserves resulting from changes in flight paths, winds, and aircraft configuration;
 - (v) The effect of fuel jettisoning on aircraft weight and fuel reserves, if applicable and approved;
 - (vi) The effect of any ice protection system, if applicable and weather conditions require its use;
 - (vii) Ambient temperatures and winds along intended route and any planned diversion; and
 - (viii) Flight paths and minimum altitudes required to remain clear of obstacles.
 - (2) During takeoff and landing—

- (i) The condition of the takeoff surface or area to be used, including any contaminants (e.g., water, slush, snow, ice on runway for landplanes; water surface conditions for seaplanes);
 - (ii) The gradient (slope) of runway to be used;
 - (iii) The runway length including clearways and stop ways, if applicable;
 - (iv) Pressure altitudes appropriate to the elevation at takeoff and landing sites;
 - (v) Current ambient temperatures and winds at takeoff;
 - (vi) Forecast ambient temperatures and winds at each destination and planned alternate landing site;
 - (vii) The ground handling characteristics (e.g., braking action) of the type of aircraft; and
 - (viii) Landing aids and terrain that may affect the takeoff path, landing path, and landing roll.
- (3) Such factors shall be taken into account directly as operational parameters or indirectly by means of allowances or margins, which may be provided in the scheduling of performance data.
- (4) Where conditions are different from those on which the performance is based, compliance may be determined by interpolation or by computing the effects of changes in the specific variables, if the results of the interpolation or computations are substantially as accurate as the results of direct tests.
- (d) To allow for wind effect, takeoff data based on still air may be corrected by taking into account not more than 50 percent of any reported headwind component and not less than 150 percent of any reported tailwind component.
- (e) The operator of the aircraft shall take such precautions as are reasonably possible to ensure that the general level of safety and risk associated with the intent of this Regulation is maintained under all expected operating conditions, including those not covered specifically by the requirements of this Part.

17.100. MASS LIMITATIONS

- (a) No person may operate an aircraft if at the mass of the aircraft at the start of takeoff would exceed the maximum mass:
- (1) Specified as limitations for that aircraft in the approved flight manual;
 - (2) That ensures safe stopping prior to reaching the takeoff safety speed;
 - (3) That ensures safe lift-off and climb after takeoff;
 - (4) The clearing of all obstacles enroute by a safe margin, considering the expected reductions in mass including fuel jettisoning;
 - (5) Required for safe landing at the destination and alternate aerodromes (or, in the case of helicopters, heliport, helideck, elevated platforms and operational sites) at the expected time of arrival;
 - (6) Required for compliance with the applicable noise certification standards for that aircraft at all aerodromes and operational sites.
- (b) All calculations relating in the determination of maximum mass shall include the pressure altitude appropriate to the elevation and, if used as a parameter to determine the maximum mass, any other local condition.
- (c) The operator may exceed the requirement of paragraph (a)(6) in locations where the competent authority of that State of the Aerodrome has authorized an exception in exceptional circumstances where there is no noise disturbance problem.

SUBPART E: AEROPLANE PERFORMANCE & OPERATING LIMITATIONS

17.105 APPLICABILITY

- (a) The Subpart is applicable to completing the performance computations for the operations of aero planes subject to this Part.

Subdivision I: Restricted Performance Aero planes

17.110. SINGLE ENGINE AERO PLANES

- (a) No person may operate a single-engine aeroplane used for passenger carrying operations in commercial air transport unless that aircraft is continually operated—
 - (1) In daylight;
 - (2) VMC, excluding over the top of any cloud layer; and
 - (3) Over such routes and diversions therefrom that permit a safe forced landing to be executed in the event of engine failure.
- (b) No person may operate a single-engine turbine-powered aircraft in passenger carrying operations in commercial air transport at night or IFR, unless has been demonstrated to the Authority that such operations will occur under a reliable level of safety and performance.

17.115. RESTRICTED PERFORMANCE MULTI-ENGINE AERO PLANES

- (a) No person may operate a restricted performance multi-engine aeroplane with a passenger capacity of 9 passengers or less in commercial air transport carrying passengers that will be unable to comply with the performance limitations of this Part, unless that aircraft is continually operated at a weight that will allow it to climb, with the critical engine inoperative—
 - (1) At least 200 feet per minute immediately after takeoff;
 - (2) At least 50 feet a minute when operating at the MEAs of the intended route or any planned diversion, or at 5,000 feet MSL, whichever is higher; and
 - (3) At least 200 feet per minute in the climb out following a balked landing.
- (b) If the performance capability of the aeroplane is computed to be less than specified in paragraph (a), the person(s) operating that aircraft shall comply with the performance restrictions applicable to single-engine aeroplane.

Subdivision II: Large or Turbine-Engined Aero planes

17.120. TAKEOFF & CLIMB PHASE

- (a) No person may commence a takeoff in aircraft unless, in the event of a critical engine failing, or for other reasons, at any point in the takeoff, the performance calculations demonstrate that is possible to—
 - (1) Discontinue the take-off and stop within either the accelerate-stop distance available or the runway available; or
 - (2) To continue the take-off and clear all obstacles along the flight path by an adequate margin as specified in paragraph (c) until the aeroplane is in a position to comply with safe enroute flight.
- (b) The determination of the length of the runway available shall take into account any loss of runway length due to alignment of the aeroplane prior to take-off.
- (c) No person may takeoff an aeroplane unless the following requirements are met when determining the maximum permitted take-off mass—
 - (1) The takeoff run shall not be greater than the length of the runway.

- (2) For turbine engine powered aero planes—
 - (i) The takeoff distance shall not exceed the length of the runway plus the length of any clearway, except that the length of any clearway included in the calculation shall not be greater than 1/2 the length of the runway; and
 - (ii) The accelerate-stop distance shall not exceed the length of the runway, plus the length of any stopway, at any time during takeoff until reaching V_1 .
- (3) *For piston engine powered aero planes—*
 - (i) The accelerate-stop distance shall not exceed the length of the runway at any time during takeoff until reaching V_1 .
- (4) If the critical engine fails at any time after the aeroplane reaches V_1 , to continue the takeoff flight path and clear all obstacles either—
 - (i) By a height of at least 9.1 m (35 ft) vertically for turbine engine powered aero planes or 15.2 m (50 ft) for piston engine powered aero planes; and
 - (ii) By at least 60 m (200 ft) horizontally within the aerodrome boundaries and by at least 90 meters (300 feet) horizontally after passing the boundaries, without banking more than 15 degrees at any point on the takeoff flight path.

17.125. ENROUTE PHASE: ALL ENGINES OPERATING

- (a) No person may take off a piston engine powered aeroplane at a weight that does not allow a rate of climb of at least $6.9 V_{so}$, (that is, the number of feet per minute obtained by multiplying the aircraft's minimum steady flight speed by 6.9) with all engines operating, at an altitude of at least 300 m (1,000 ft) above all terrain and obstructions within ten miles of each side of the intended track.

17.130. ENROUTE PHASE: ONE ENGINE INOPERATIVE

- (a) No person may commence a takeoff unless the performance calculations demonstrate that the aircraft can, in the event of the critical engine becoming inoperative at any point along the route or planned diversions therefrom, continue the flight to an aerodrome where a landing within the safety margins specified in Regulation 17.150 without flying below the minimum obstacle clearance altitude at any point.
- (b) No person may take off an aeroplane having two engines unless that aeroplane can, in the event of a power failure at the most critical point en route, continue the flight to a suitable aerodrome where a landing can be made while allowing—
 - (1) *For piston engine powered aero planes—*
 - (i) At least a rate of climb of $0.079 - (0.106/\text{number of engines installed}) V_{so}^2$ (when V_{so} is expressed in knots) at an altitude of 300 m (1,000 ft) above all terrain and obstructions within 9.3 km (5 sm), on each side of the intended track; and
 - (ii) A positive slope at an altitude of at least 450 m (1,500 ft) above the aerodrome where the aeroplane is assumed to land.
 - (2) *For turbine engine powered transport category aero planes—*
 - (i) A positive slope at an altitude of at least 300 m (1,000 ft) above all terrain and obstructions within 9.3 km (5 sm), on each side of the intended track;
 - (ii) A net flight path from cruising altitude to the intended landing aerodrome that allows at least 600 m (2,000 ft) clearance above all terrain and obstructions within 9.3 km (5 sm), on each side of the intended track; and
 - (iii) A positive slope at an altitude of at least 450 m (1,500 ft) above the aerodrome where the aeroplane is assumed to land.
- (c) The climb rate specified in paragraph (b)(1)(i) may be amended to $0.026 V_{so}^2$ for large transport category aircraft issued a type certificate prior to 1953.

Civil Aviation Regulations

- (d) The 9.3 km (5 sm) clearance margin stated in paragraph (a) shall be increased to 18.5 km (10 sm) if navigational accuracy does not meet the 95% containment level.

17.135. ENROUTE PHASE: TWO ENGINES INOPERATIVE

- (a) No person may takeoff an aeroplane having three or more engines at such a weight where there is no suitable landing aerodrome within 90 minutes at any point along the intended route (with all engines operating at cruising power), unless that aircraft can, in the event of simultaneous power failure of two critical engines at the most critical point along that route, continue to a suitable landing aerodrome while allowing—
- (1) For turbine engine powered aero planes—
 - (i) A net flight path (considering the ambient temperatures anticipated along the track) clearing vertically by at least 2,000 feet all terrain and obstructions within five statute miles (4.34 nautical miles) on each side of the intended track;
 - (ii) A positive slope at 1,500 feet above the aerodrome of intended landing; and
 - (iii) Enough fuel to continue to the aerodrome of intended landing, to arrive at an altitude of at least 1,500 feet directly over the aerodrome, and thereafter to fly for 15 minutes at cruise power.
 - (2) For piston engine powered aero planes—
 - (i) A rate of climb at $0.013 V_{so}^2$ feet per minute (that is, the number of feet per minute is obtained by multiplying the number of knots squared by 0.013) at an altitude of 1,000 feet above the highest ground or obstruction within 10 miles on each side of the intended track, or at an altitude of 5,000 feet, whichever is higher; and
 - (ii) Enough fuel to continue to the aerodrome of intended landing and to arrive at an altitude of at least 300 m (1,000 ft) directly over that aerodrome.
- (b) The performance calculation shall consider that the consumption of fuel and oil after the engine failure is the same as the consumption that is allowed for in the net flight path data in the AFM.
- (c) When the two engines of the piston aeroplane are predicted to fail at an altitude above the prescribed minimum altitude, compliance with the prescribed rate of climb need not be shown during the descent from the cruising altitude to the prescribed minimum altitude, if those requirements can be met once the prescribed minimum altitude is reached, and assuming descent to be along a net flight path and the rate of descent to be $0.013 V_{so}^2$ greater than the rate in the approved performance data.
- (d) If fuel jettisoning is authorized (or planned), the aero plane's weight at the point where the two engines fail is considered to be not less than that which would include enough fuel to proceed to an aerodrome and to arrive at an altitude of at least 300 m (1,000 ft) directly over that aerodrome.

17.140. APPROACH & LANDING PHASE

- (a) The operator shall assess the performance data to ensure that the aeroplane, at the aerodrome of intended landing and at any alternate aerodrome, after clearing all obstacles in the approach path by a safe margin, will be able to land, with assurance that it can come to a stop or, for a seaplane, to a satisfactorily low speed, within the landing distance available, in compliance with the requirements of this Regulation.
- (b) The operator shall make allowance for expected variations in the approach and landing techniques, if such allowance has not been made in the scheduling of the manufacturer's performance data.
- (c) No person may take off an aeroplane used in commercial operations unless its weight on

arrival at either the intended destination aerodrome or any planned alternate aerodrome would allow a full stop landing from a point 50 feet above the intersection of the obstruction clearance plane and the runway, and within—

- (1) For turbine engine powered aero planes, 60 percent of the effective length of each runway.
 - (2) For piston engine powered aero planes, 70 percent of the effective length of each runway.
- (d) For the purpose of determining the allowable landing weight at the destination aerodrome, each person determining the landing limit shall ensure that—
- (1) The aeroplane is landed on the most favorable runway and in the most favorable direction, in still air; or
 - (2) The aeroplane is landed on the most suitable runway considering the probable wind velocity and direction, runway conditions, the ground handling characteristics of the aeroplane, and considering other conditions such as landing aids and terrain.
- (e) If the runway at the landing destination is reported or forecast to be wet or slippery, the landing distance available shall be at least 115 percent of the required landing distance unless, based on a showing of actual operating landing techniques on wet or slippery runways, a shorter landing distance (but not less than that required by paragraph (a)) has been approved for a specific type and model aeroplane and this information is included in the AFM.
- (f) A turbine powered transport category aeroplane that would be prohibited from taking off because it could not meet the requirements of paragraph (c)(1), may take off if an alternate aerodrome is specified that meets all the requirements of paragraph (a).

The Remainder of This Page Intentionally Left Blank

SUBPART F: HELICOPTER PERFORMANCE & OPERATING LIMITATIONS

17.145. APPLICABILITY

- (a) The Subpart is applicable to completing the performance computations for the operations of helicopters subject to this Part.

Subdivision I: Helicopter—General

17.150. PERFORMANCE REQUIREMENTS BASED ON PASSENGER CONFIGURATION

- (a) No person may operate a helicopter with a passenger seating configurations of more than 19, unless that helicopter is operated in accordance with the requirements for performance Class 1.
- (b) No person may operate a helicopter with a passenger seating configuration of 19 or less but more than 9, unless that helicopter is operated in accordance with the requirements of performance Class 1 or 2.
- (c) No person may operate a helicopter with a passenger seating configuration of 9 or less unless that helicopter is operated in accordance with the requirements of performance Class 1, 2 or 3

Note: Refer to Regulation 10.513 for the more restrictive requirements regarding operations of operating any Performance Class 2 or 3 helicopter i within a congested hostile environment.

- (d) The Authority may issue a waiver to one or more of these requirements based on a risk assessment that considers the extenuating factors that provide an equivalent level of safety including—
 - (1) The type of operation and the circumstances of the flight;
 - (2) The area/terrain over which the flight is being conducted;
 - (3) The probability of a critical power-unit failure and the consequence of such an event;
 - (4) The procedures to maintain the reliability of the power-unit(s);
 - (5) The training and operational procedures to mitigate the consequences of the critical power-unit failure; and
 - (6) Installation and utilization of a usage monitoring system.

17.155. ACCOUNTABILITY FOR WIND

- (a) In addition to the requirements of Subpart C and D, to determine the performance of the helicopter for take- off and landing, accountability for wind should be no more than 50 per cent of any reported steady headwind component of 5 knots or more—
 - (1) Where take-off and landing with a tailwind component is permitted in the flight manual, not less than 150 per cent of any reported tailwind component should be allowed.
 - (2) Where precise wind measuring equipment enables accurate measurement of wind velocity over the point of take-off and landing, these values may be varied.

17.160. OBSTACLE ACCOUNTABILITY AREA

- (a) In addition to the requirements of Regulation 17.090, for the purpose of the obstacle clearance requirements, an obstacle should be considered if its lateral distance from the nearest point on the surface below the intended flight path is not further than—
 - (1) For VFR operations: Half of the minimum width of the FATO (or the equivalent term used in the helicopter flight manual) defined in the helicopter flight manual (or when no width is defined, 0.75 D), plus 0.25 times D (or 3 m, whichever is greater), plus—
 - (i) 0.10 DR for VFR day operations

- (ii) 0.15 DR for VFR night operations
- (2) For IFR operations: 1.5 D (or 30 m, whichever is greater), plus—
 - (i) 0.10 DR for IFR operations with accurate course guidance
 - (ii) 0.15 DR for IFR operations with standard course guidance
 - (iii) 0.30 DR for IFR operations without course guidance
- (b) For operations with initial take-off conducted visually and converted to IFR/IMC at a transition point—
 - (1) The criteria required in paragraph (a)(1) applies up to the transition point; then
 - (2) The criteria required in paragraph (a)(2) applies after the transition point.
- (c) For a take-off using a backup take-off procedure (or with lateral transition), for the purpose of the obstacle clearance requirements in paragraph (d)(4) below, an obstacle located below the backup flight path (lateral flight path) should be considered if its lateral distance from the nearest point on the surface below the intended flight path is not further than half of the minimum width of the FATO (or the equivalent term used in the helicopter flight manual) defined in the helicopter flight manual (when no width is defined, 0.75 D plus 0.25 times D, or 3 m, whichever is greater) plus—
 - (i) 0.10 distance travelled from the back edge of the FATO for VFR day operations;
 - (ii) 0.15 distance travelled from the back edge of the FATO for VFR night operations.
- (d) Obstacles may be disregarded if they are situated beyond—
 - (1) 7 R for day operations if it is assured that navigational accuracy can be achieved by reference to suitable visual cues during the climb;
 - (2) 10 R for night operations if it is assured that navigational accuracy can be achieved by reference to suitable visual cues during the climb;
 - (3) 300 m if navigational accuracy can be achieved by appropriate navigation aids; and
 - (4) 900 m in the other cases.

Note. — Standard course guidance includes ADF and VOR guidance. Accurate course guidance includes ILS, MLS, or other course guidance providing an equivalent navigational accuracy.
- (e) The transition point should not be located before the end of TODRH for helicopters operating in performance Class 1 and before the DPATO for helicopters operating in performance Class 2.
- (f) When considering the missed approach flight path, the divergence of the obstacle accountability area should only apply after the end of the take-off distance available.

17.165. FATO OPERATING AREA CONSIDERATIONS

- (a) For operations in performance Class 1, the dimensions of the FATO should be at least equal to the dimensions specified in the helicopter flight manual.
- (b) A FATO that is smaller than the dimensions specified in the helicopter flight manual may be accepted if the helicopter is capable of a hover out of ground effect with one engine inoperative (HOGE OEI).

Subdivision II: Operations in Performance Class 1

17.170. DEFINITIONS

- (a) The following definition are applicable only to operations in Performance Class 1—
 - (1) **Landing distance required (LDRH).** The horizontal distance required to land and come to a full stop from a point 15 m (50 ft) above the landing surface.
 - (2) **Rejected take-off distance required (RTODR).** The horizontal distance required from the start of the take-off to the point where the helicopter comes to a full stop following a power-unit failure and rejection of the take-off at the take-off decision point.

Civil Aviation Regulations

- (3) **Take-off distance required (TODRH).** The horizontal distance required from the start of the take-off to the point at which V_{T0SS} , a selected height and a positive climb gradient are achieved, following failure of the critical power-unit being recognized at TDP, the remaining power-units operating within approved operating limits. The selected height shall be determined with reference to either—
- The take-off surface; or
 - A level defined by the highest obstacle in the take-off distance required.

17.175. TAKEOFF & INITIAL CLIMB PHASE: PERFORMANCE CLASS 1

- (a) The helicopter shall be able, in the event of the failure of the critical power-unit being recognized at or before the take-off decision point to—
- Discontinue the take-off and stop within the rejected take-off area available; or
 - In the event of the failure of the critical power-unit being recognized at or after the take-off decision point, to continue the take-off, clearing all obstacles along the flight path by an adequate margin until the helicopter is in a position to comply with Regulation 17.215.
- (b) To meet the requirement of paragraph (a)(1), the computed take-off mass shall indicate that the rejected take-off distance required will not exceed the rejected take-off distance available.
- (c) To meet the requirement of paragraph (a)(2), the computed take-off mass shall indicate that the take-off distance required will not exceed the take-off distance available.
- (d) The computed take-off mass shall indicate that the helicopter will not exceed the maximum take-off mass specified in the flight manual for the procedure to be used and to achieve a rate of climb of 100 ft/min at 60 m (200 ft) and 150 ft/min at 300 m (1 000 ft) above the level of the heliport with the critical engine inoperative and the remaining power-units operating at an appropriate power rating.

Refer to Appendix 1 to 17.195 for a graphic presentation of the requirement of this Regulation.

- (e) As an alternative, the requirement above may be disregarded provided that the helicopter with the critical power-unit failure recognized at TDP can, when continuing the take-off, clear all obstacles from the end of the take-off distance available to the end of the take-off distance required by a vertical margin of not less than 10.7 m (35 ft)

Refer to Appendix 2 to 17.195 for a graphic presentation of the alternative requirement of this Regulation.

- (f) For elevated heliports, the appropriate clearance from the elevated heliport edge shall be considered in the performance computation.

Refer to Appendix 3 to 17.195 for a graphic presentation of the requirement of this Regulation.

17.180. TAKEOFF FLIGHT PATH: PERFORMANCE CLASS 1

- (a) From the end of the take-off distance required with the critical power-unit inoperative. the computed take-off mass shall indicate that the climb path provides a vertical clearance above all obstacles located in the climb path of not less than—
- 10.7 m (35 ft) for VFR operations; and
 - 10.7 m (35 ft) plus 0.01 DR for IFR operations.
- (b) Only obstacles as specified in 17.215 should be considered.
- (c) Where a change of direction of more than 15 degrees is made, obstacle clearance requirements should be increased by 5 m (15 ft) from the point at which the turn is initiated.
- (d) The turn in paragraph (c) should not be initiated before reaching a height of 60 m (200 ft) above the take-off surface, unless permitted as part of an approved procedure in the flight

manual.

17.185. ENROUTE PHASE: PERFORMANCE CLASS 1: PERFORMANCE CLASS 1

- (a) The helicopter shall be able, in the event of the failure of the critical power-unit at any point in the enroute phase—
 - (1) To continue the flight to a site at which the performance requirements for Regulation 17.215 can be met;
 - (2) Without flying below the appropriate minimum flight altitude at any point.
- (b) The computed take-off mass shall indicate that it is possible, in case of the critical power-unit failure occurring at any point of the flight path, to continue the flight to an appropriate landing site and achieve the minimum flight altitudes for the route to be flown.

117.190. ENROUTE PHASE: TWO ENGINES INOPERATIVE: PERFORMANCE CLASS 1

- (a) No person shall takeoff a Class 1 helicopter having three or more engines unless that helicopter can, in the event of two critical engines failing simultaneously at any point in the enroute phase, continue the flight to a suitable landing site.

17.195. APPROACH & LANDING PHASE: PERFORMANCE CLASS 1

- (a) In the event of the failure of the critical power-unit being recognized at any point during the approach and landing phase, before the landing decision point, the helicopter shall be able—
 - (1) At the destination and at any alternate;
 - (2) After clearing all obstacles in the approach path;
 - (3) Land and stop within the landing distance available; or
 - (4) To perform a balked landing and clear all obstacles in the flight path by an adequate margin equivalent to that specified in Regulation 17.195.
- (b) In case of the failure occurring after the landing decision point, the helicopter shall be able to land and stop within the landing distance available.
- (c) No person may take-off a helicopter unless the computed landing mass at the destination or alternate indicates that—
 - (1) The helicopter will not exceed the maximum landing mass specified in the flight manual for the procedure to be used and to achieve a rate of climb of 100 ft/min at 60 m (200 ft) and 150 ft/min at 300 m (1 000 ft) above the level of the heliport with the critical engine inoperative and the remaining power-units operating at an appropriate power rating;
 - (2) The landing distance required does not exceed the landing distance available unless the helicopter, with the critical power-unit failure recognized at LDP can, when landing, clear all obstacles in the approach path;
 - (3) In case of the critical power-unit failure occurring at any point after the LDP, it will be possible to land and stop within the FATO; and
 - (4) In the event of the critical power-unit failure being recognized at the LDP or at any point before the LDP, it will be possible either to land and stop within the FATO or to overshoot, meeting the conditions of 17.195.

Refer to Appendices 1 and 2 to 17.215 for graphic presentation of these requirements for landings at both surface and elevated heliports.

Subdivision III: Operations in Performance Class 2

17.200. TAKEOFF & CLIMB PHASE: PERFORMANCE CLASS 2

- (a) The helicopter shall be able, in the event of the failure of the critical power-unit at any time after reaching DPATO, to continue the take-off, clearing all obstacles along the flight path by an adequate margin until the helicopter is in a position to comply with Regulation 17.225.
- (b) Before the DPATO, failure of the critical power-unit may cause the helicopter to force-land; therefore, the helicopter operations shall be conducted in a manner that gives appropriate consideration for achieving a safe forced landing.
- (c) The computed mass of the helicopter at take-off shall not exceed the maximum take-off mass specified in the flight manual for the procedures to be used and to achieve a rate of climb of 150 ft/min at 300 m (1 000 ft) above the level of the heliport with the critical power-unit inoperative and the remaining power-units operating at an appropriate power rating.

Refer to Appendices 1 and 2 to 17.220 for a graphic presentation of the requirements of this Regulation.

- (d) From DPATO or, as an alternative, no later than 60 m (200 ft) above the take-off surface with the critical power-unit inoperative—
 - (1) Where a change of direction of more than 15 degrees is made, obstacle clearance requirements should be increased by 5 m (15 ft) from the point at which the turn is initiated.
 - (2) The turn in paragraph (d)(1) should not be initiated before reaching a height of 60 m (200 ft) above the take-off surface, unless permitted as part of an approved procedure in the flight manual.

17.205. ENROUTE PHASE: PERFORMANCE CLASS 2

- (a) The helicopter shall be able, in the event of the failure of the critical power-unit at any point in the enroute phase—
 - (1) To continue the flight to a site at which the performance requirements for Regulation 17.235 can be met; and
 - (2) Without flying below the appropriate minimum flight altitude at any point.

17.210. ENROUTE PHASE: TWO ENGINES INOPERATIVE: PERFORMANCE CLASS 2

- (a) No person shall takeoff a Class 2 helicopter having three or more engines unless that helicopter can, in the event of two critical engines failing simultaneously at any point in the en route phase, continue the flight to a suitable landing site.

17.215. APPROACH & LANDING PHASE: PERFORMANCE CLASS 2

- (a) In the event of the failure of the critical power-unit before the DPBL, the computations of mass shall indicate that the helicopter should be able—
 - (1) At the destination and at any alternate;
 - (2) After clearing all obstacles in the approach path;
 - (3) Either to land and stop within the landing distance available; or
 - (4) To perform a bailed landing and clear all obstacles in the flight path by an adequate margin equivalent to that specified in Regulation 17.220.

Refer to Appendix 1 and 2 to 17.235 for graphic presentations of the requirements of this Regulation.

- (b) After the DPBL, failure of a power-unit may cause the helicopter to force-land; therefore, the helicopter operations shall be conducted in a manner that gives appropriate consideration for achieving a safe forced landing.

Subdivision IV: Operations in Performance Class 3**17.220. GENERAL RESTRICTION: PERFORMANCE CLASS 3**

- (a) Unless otherwise authorized by the Authority, all operations of helicopters in Performance Class 3 shall be conducted in a non-hostile environment.
- (b) Unless the Authority grants specific approval, no person may operate a helicopter in Performance Class 3 operations in commercial air transport—
 - (1) Out of the sight of the surface; or
 - (2) At night;
 - (3) When the cloud ceiling is less than 180 m (600 ft);
 - (4) When the takeoff and enroute visibility is less than 800m; or
 - (5) In instrument meteorological conditions.

17.225. TAKEOFF & CLIMB PHASE: OPERATIONS IN PERFORMANCE CLASS 3

- (a) At any point of the takeoff and climb flight path, failure of a power-unit will cause the helicopter to force- land; therefore, the helicopter operations shall be conducted in a manner that gives appropriate consideration for achieving a safe forced landing.
- (b) Except as provided in paragraph (c), the computed mass of the helicopter at take-off shall not exceed the maximum take-off mass specified in the flight manual for a hover in ground effect with all power-units operating at take-off power.
- (c) If conditions are such that a hover in ground effect is not likely to be established, the take-off mass shall not exceed the computed maximum mass specified for a hover out of ground effect with all power-units operating at take-off power.
- (d) The computed take-off mass shall indicate that the climb path provides adequate vertical clearance above all obstacles located along the climb path, all engines operating.

17.230. ENROUTE PHASE: OPERATIONS IN PERFORMANCE CLASS 3

- (a) The helicopter shall be able, with all power-units operating, to continue along its intended route or planned diversions without flying at any point below the appropriate minimum flight altitude.
- (b) At any point of the enroute flight path, failure of a power-unit will cause the helicopter to force-land; therefore, the helicopter operations shall be conducted in a manner that gives appropriate consideration for achieving a safe forced landing.
- (c) The computed take-off mass shall indicate that it is possible to achieve the minimum flight altitudes for the route to be flown, all engines operating.

17.235. APPROACH & LANDING PHASE: OPERATIONS IN PERFORMANCE CLASS 3

- (a) At any point of the approach and landing flight path, failure of a power-unit will cause the helicopter to force- land; therefore, the helicopter operations shall be conducted in a manner that gives appropriate consideration for achieving a safe forced landing.
- (b) The computed landing mass at the destination or alternate shall be such that—
 - (1) It does not exceed the maximum landing mass specified in the flight manual for a hover in ground effect with all power-units operating at take-off power;
 - (2) If conditions are such that a hover in ground effect is not likely to be established, the take-off mass should not exceed the maximum mass specified for a hover out of ground effect with all power-units operating at take-off power;
 - (3) It is possible to perform a bailed landing, all engines operating, at any point of the flight path and clear all obstacles by an adequate vertical interval.

APPENDICES

APPENDIX 1 TO 17.003.- SUMMARY OF AMENDMENTS AND REVISION HIGHLIGHTS

This Appendix contains a summary of all amendments and revision highlights to this Part since the issuance of the original regulation.

Amended Regulation	Source of Amendment	Revision	Description of Revision
17.003	Internal	Special Regulation RSR/01/2020 Effective 15 November 2020	Inserted a new summary of Amendments and Highlight of Revisions.
Appendix 1 to 17.003	Internal	Special Regulation RSR/01/2020 Effective 15 November 2020	Added a new Appendix providing details to the summary of Amendments and Highlight of Revisions.

New: Internal: Special Regulation RSR/01/2020: Effective 15 November 2020

APPENDIX 1 TO 17.195: SURFACE LEVEL TAKEOFF: PERFORMANCE CLASS 1

This graphic provides a visual diagram of the requirements of Regulation 17.195—

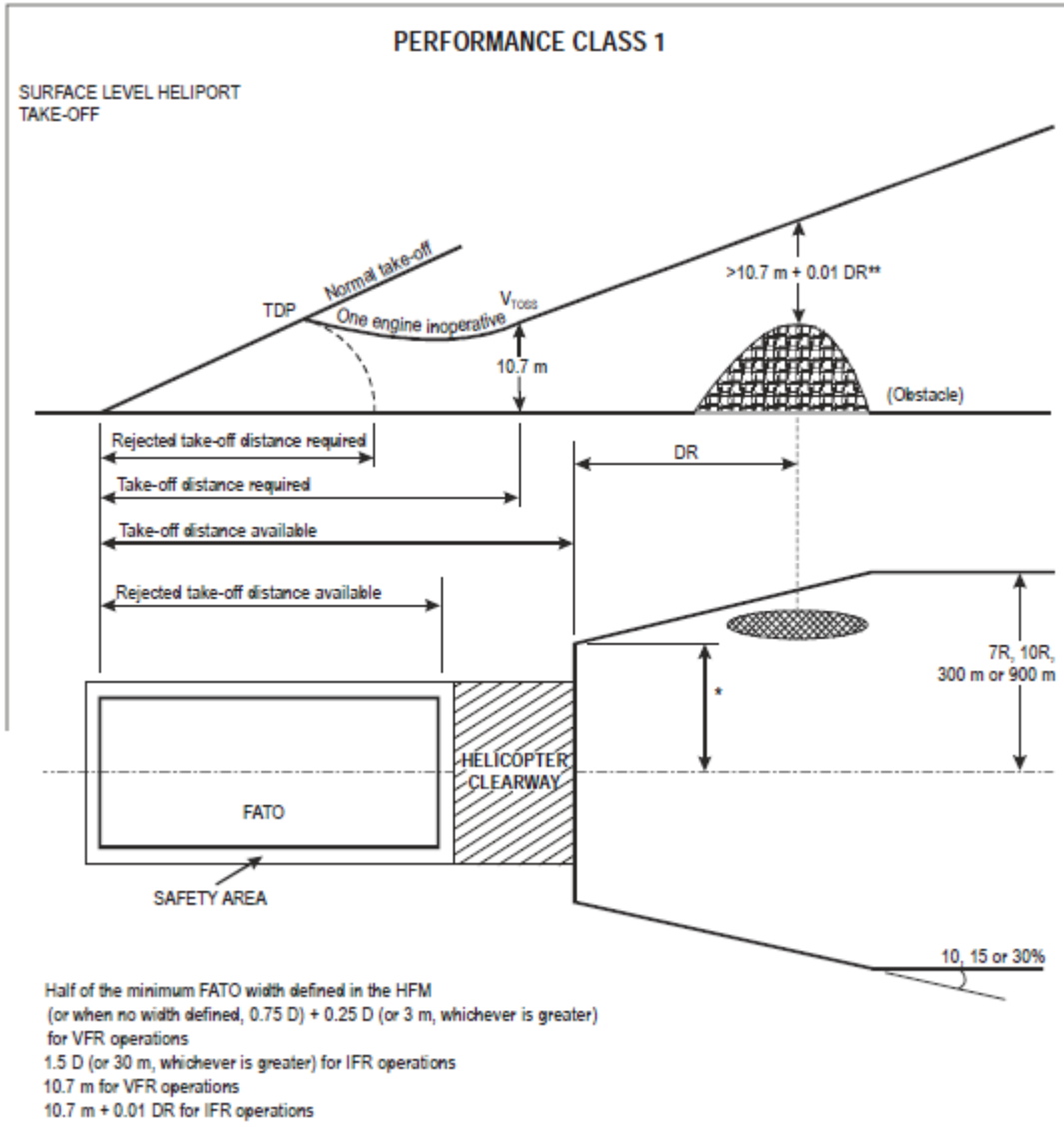

The Remainder of this page intentionally left blank

Civil Aviation Regulations

APPENDIX 2 TO 17.195: ALTERNATIVE SURFACE TAKEOFF: PERFORMANCE CLASS 1

This graphic provides a visual diagram of the alternative requirements of this Regulation 17.195—

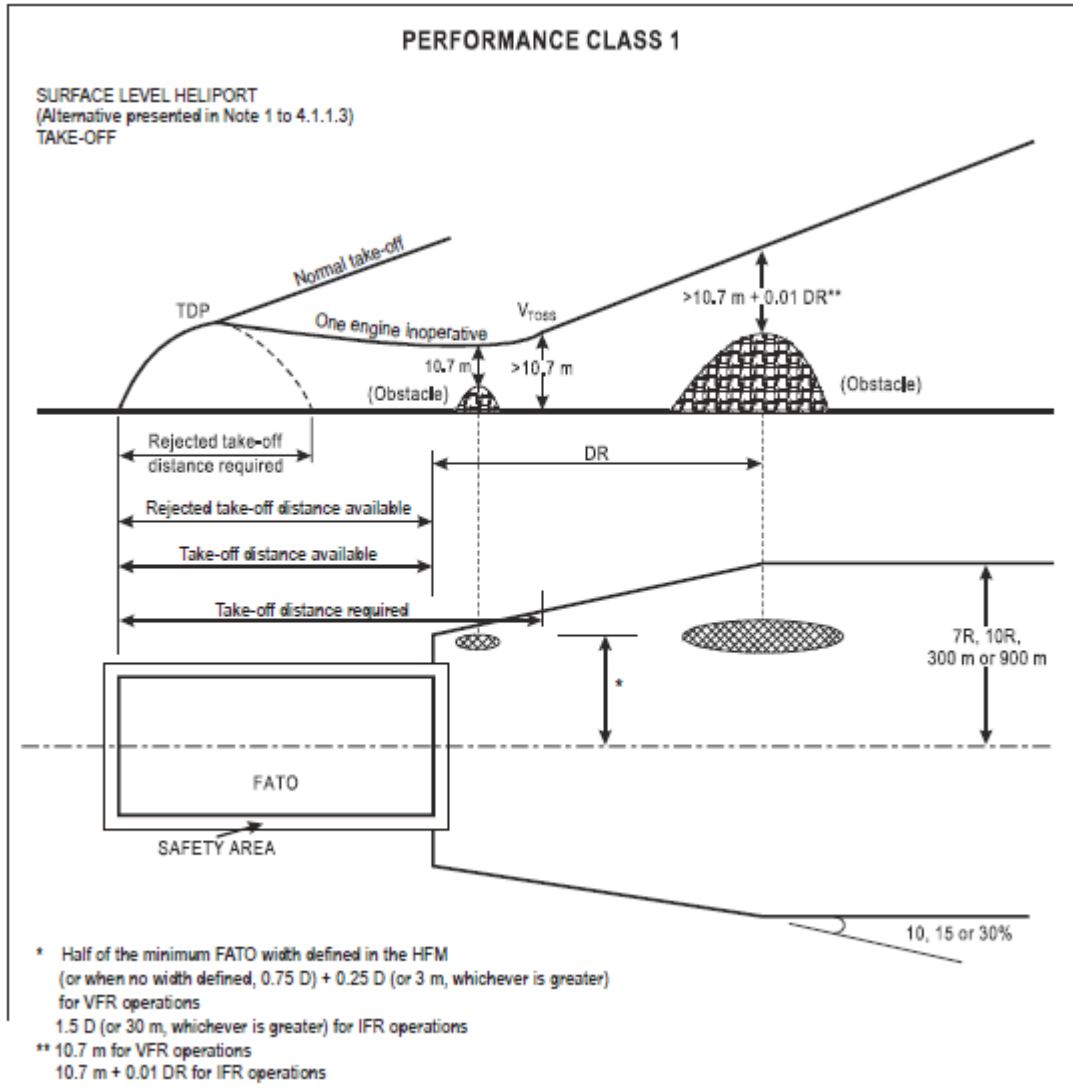

The Remainder of this page intentionally left blank

APPENDIX 3 TO 17.195: ELEVATED TAKEOFF

This graphic provides a visual diagram of the requirements of Regulation 17.195—

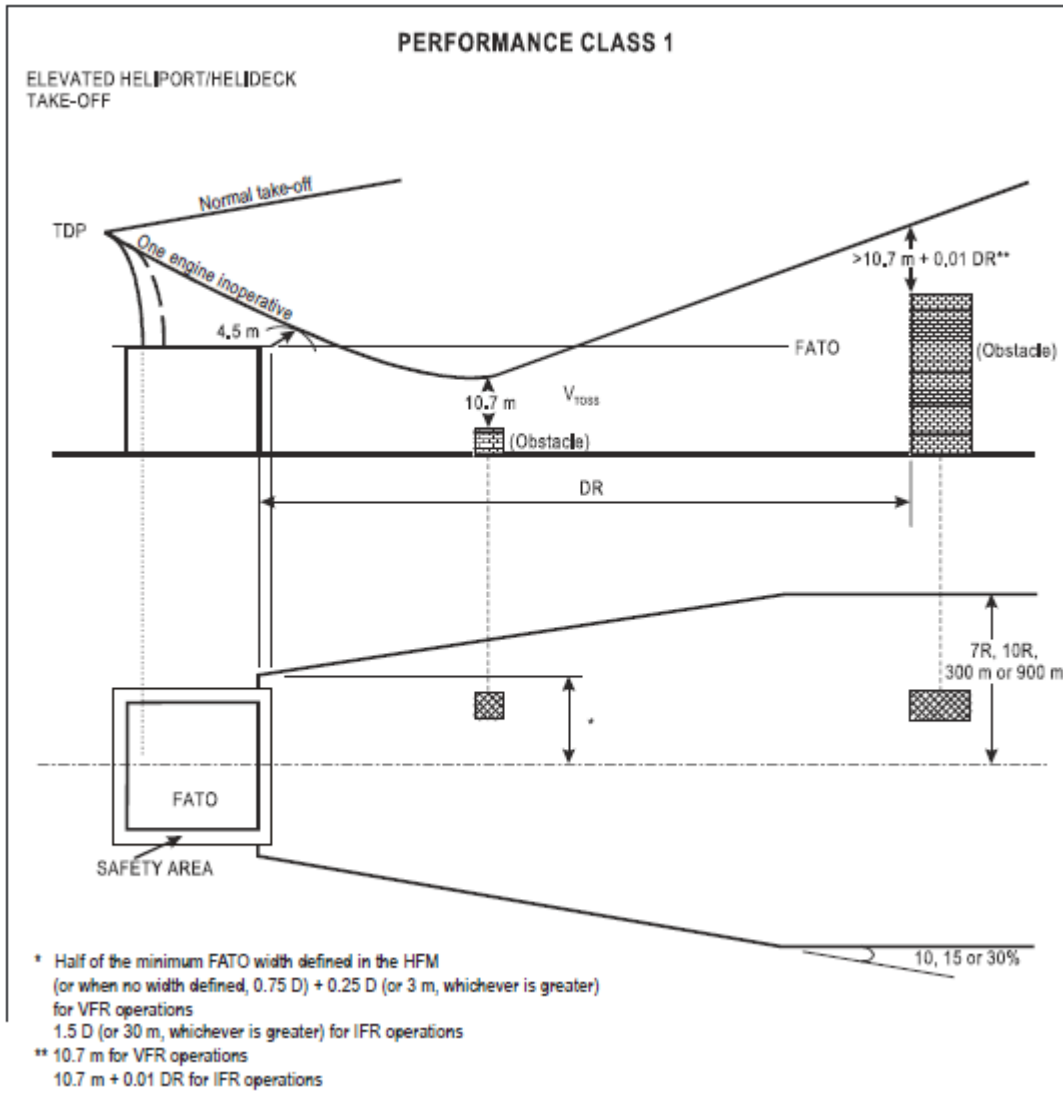

The Remainder of this page intentionally left blank

Civil Aviation Regulations

APPENDIX 1 TO 17.215: SURFACE LEVEL LANDING: PERFORMANCE CLASS 1

This graphic provides a visual diagram of the requirements of this Regulation 17.215—

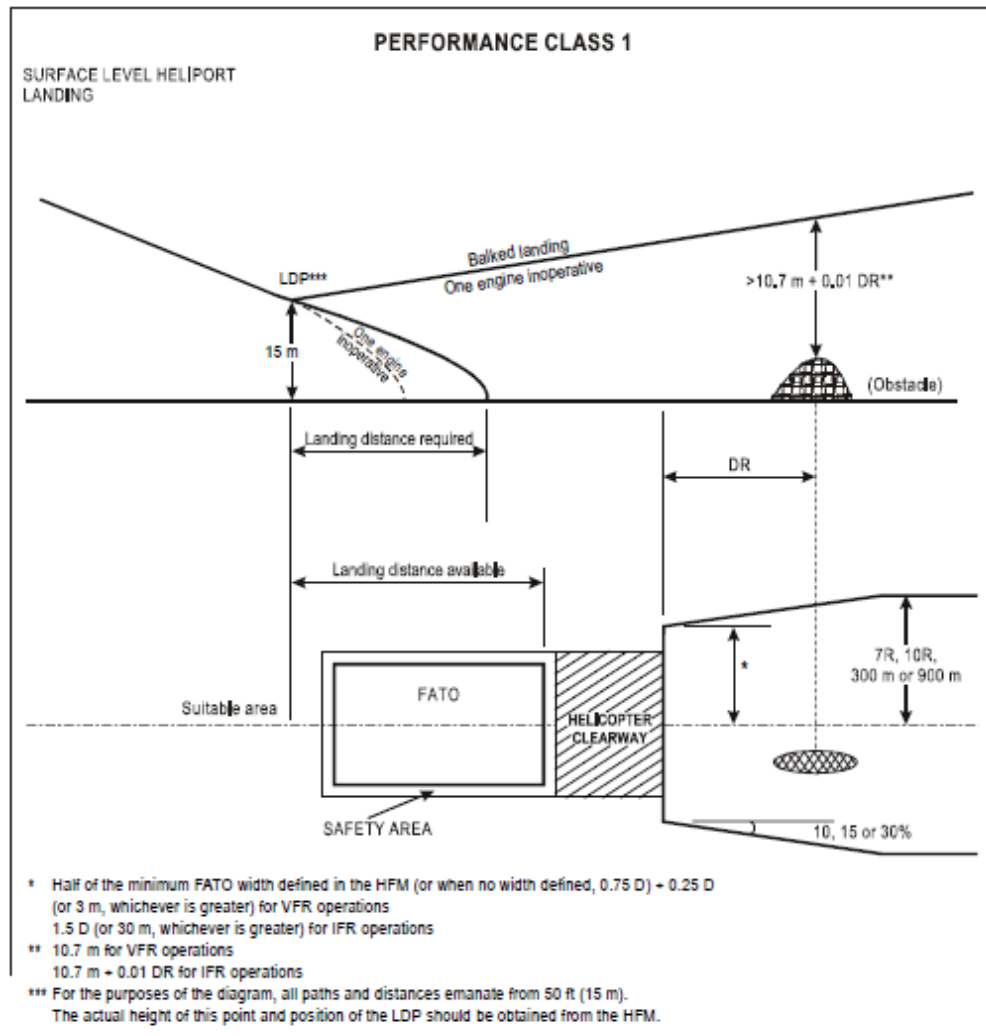

The Remainder of this page intentionally left blank

APPENDIX 2 TO 17.215: ELEVATED LANDING: PERFORMANCE CLASS 1

This graphic provides a visual diagram of the requirements of this Regulation 17.215—

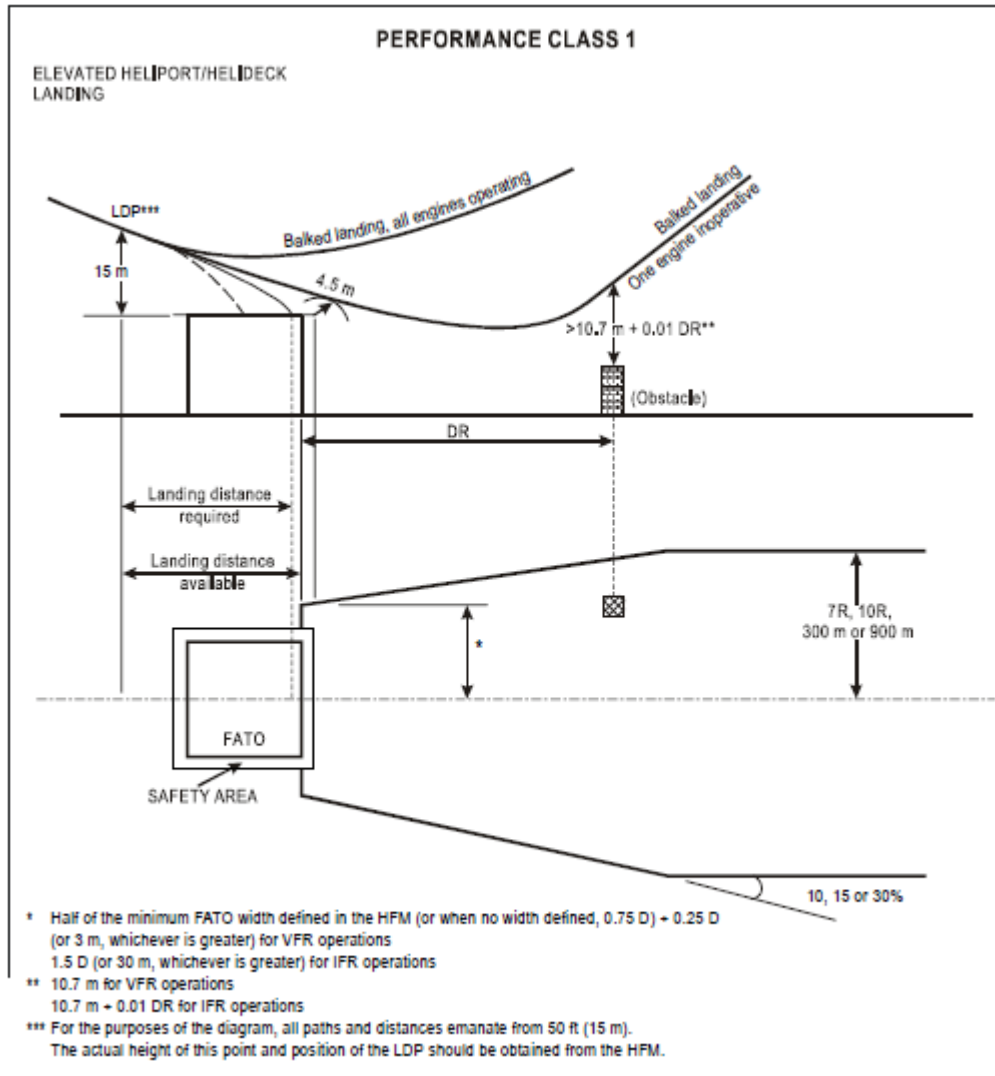

The Remainder of this page intentionally left blank

APPENDIX 1 TO 17.220: SURFACE LEVEL TAKEOFF: PERFORMANCE CLASS 2

This graphic provides a visual diagram of the requirements of Regulation 17.220—

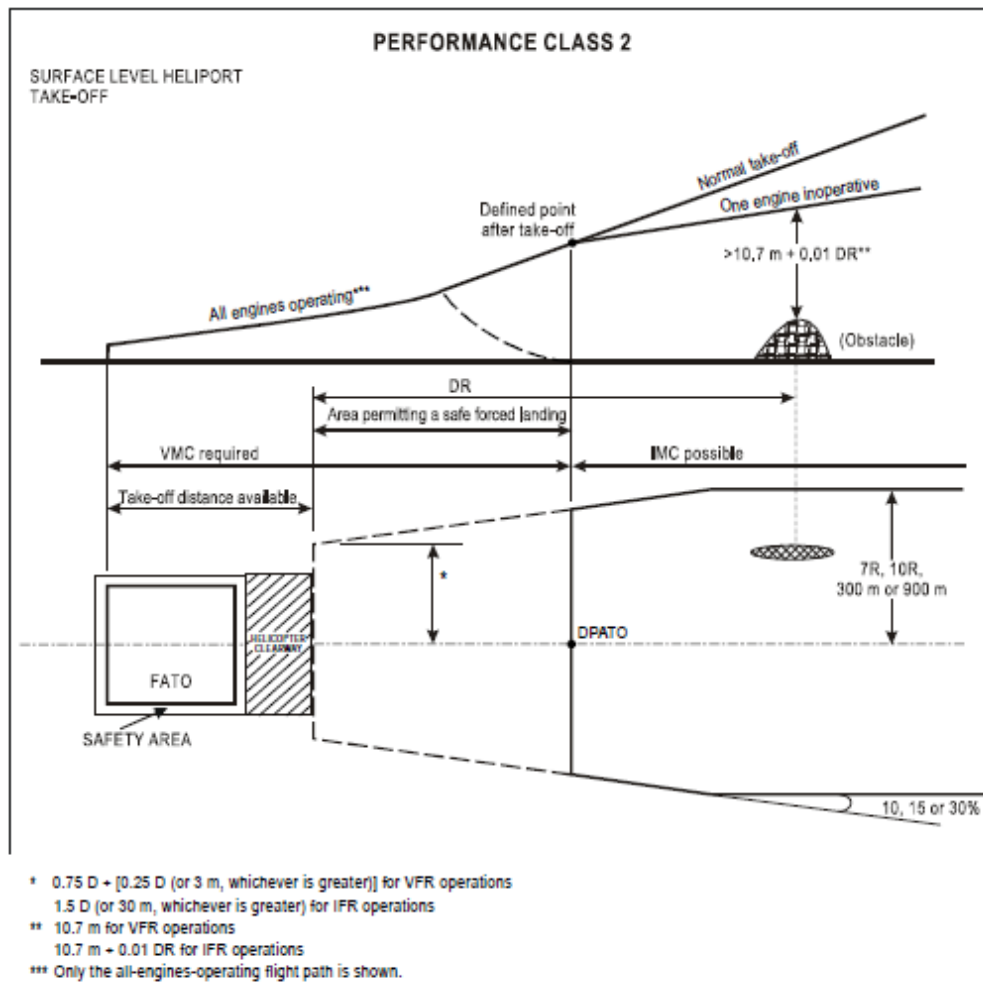

The Remainder of this page intentionally left blank

APPENDIX 2 TO 17.220: ELEVATED TAKEOFF: PERFORMANCE CLASS 2

This graphic provides a visual diagram of the requirements of Regulation 17.220 —

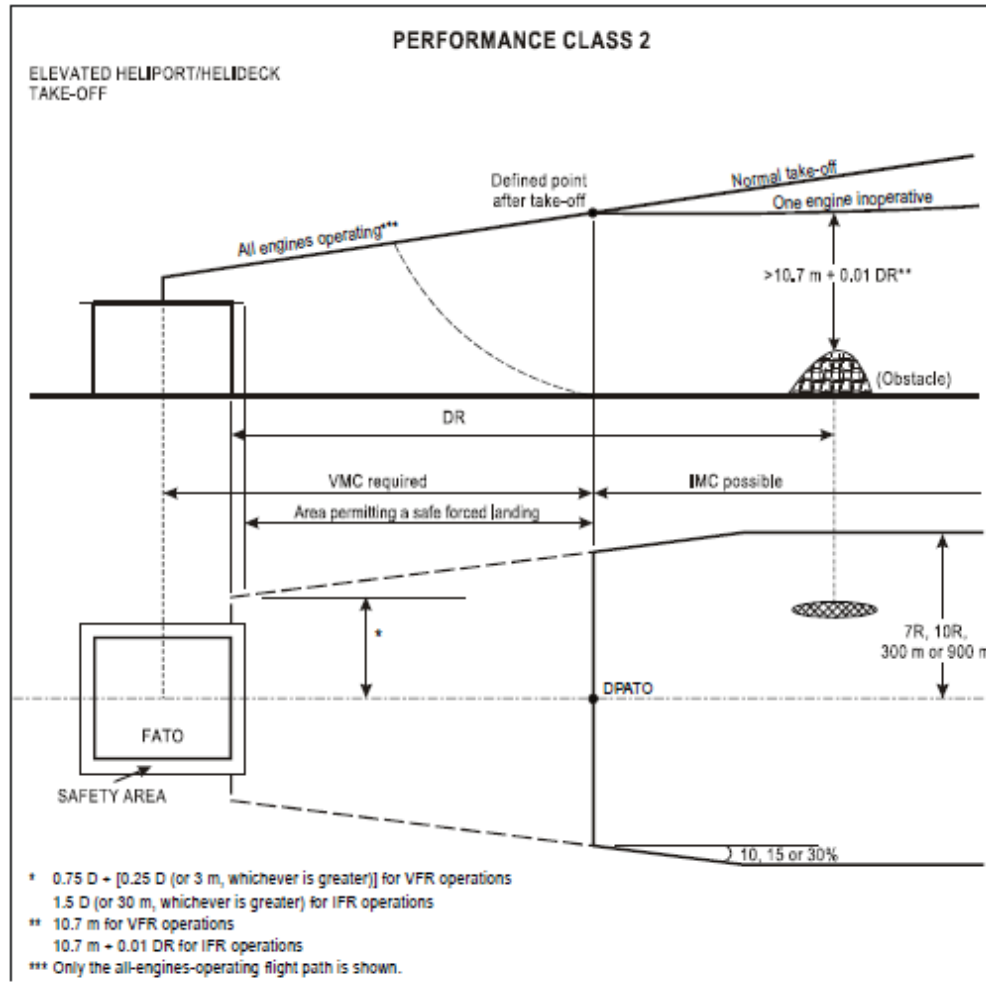

The Remainder of this page intentionally left blank

Civil Aviation Regulations

APPENDIX 1 TO 17.235: SURFACE LEVEL LANDING: PERFORMANCE CLASS 2

This graphic provides a visual diagram of the requirements of Regulation 17.235—

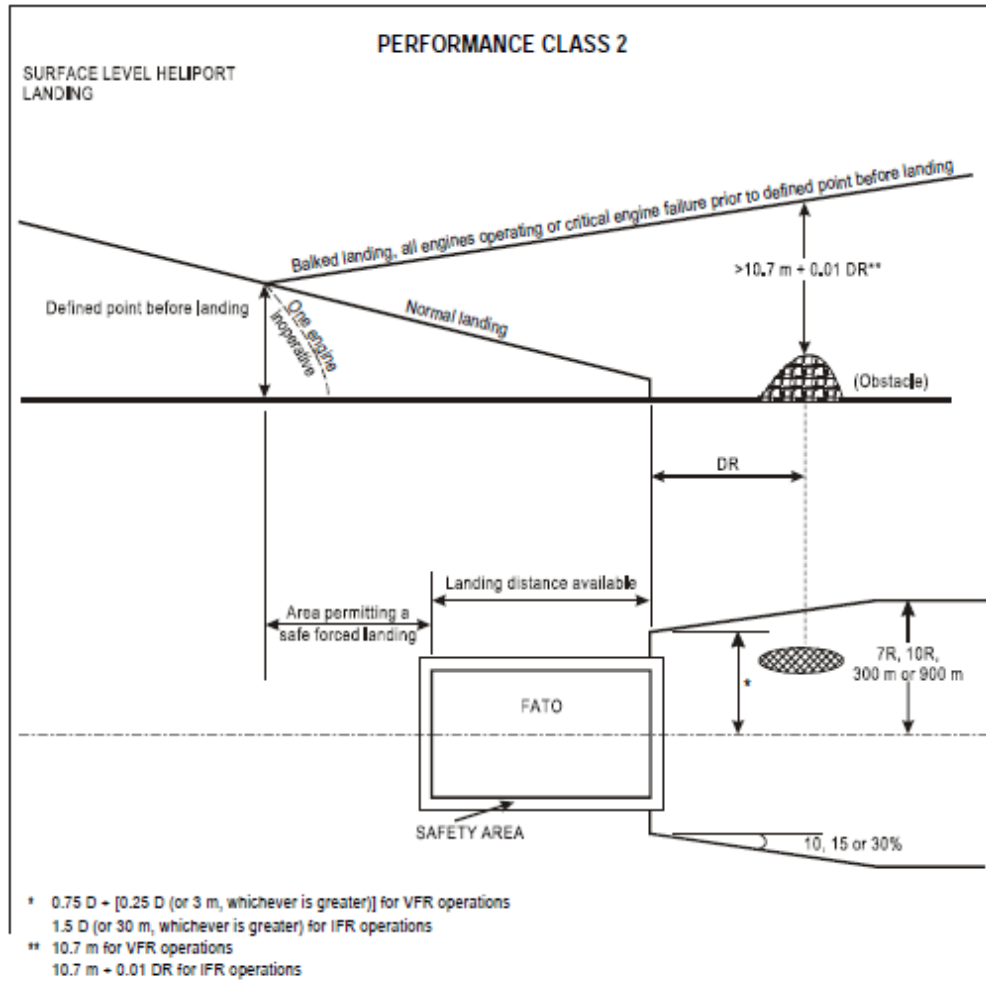

The Remainder of this page intentionally left blank

APPENDIX 2 TO 17.235: ELEVATED LANDING: PERFORMANCE CLASS 2

This graphic provides a visual diagram of the requirements of Regulation 17.235—

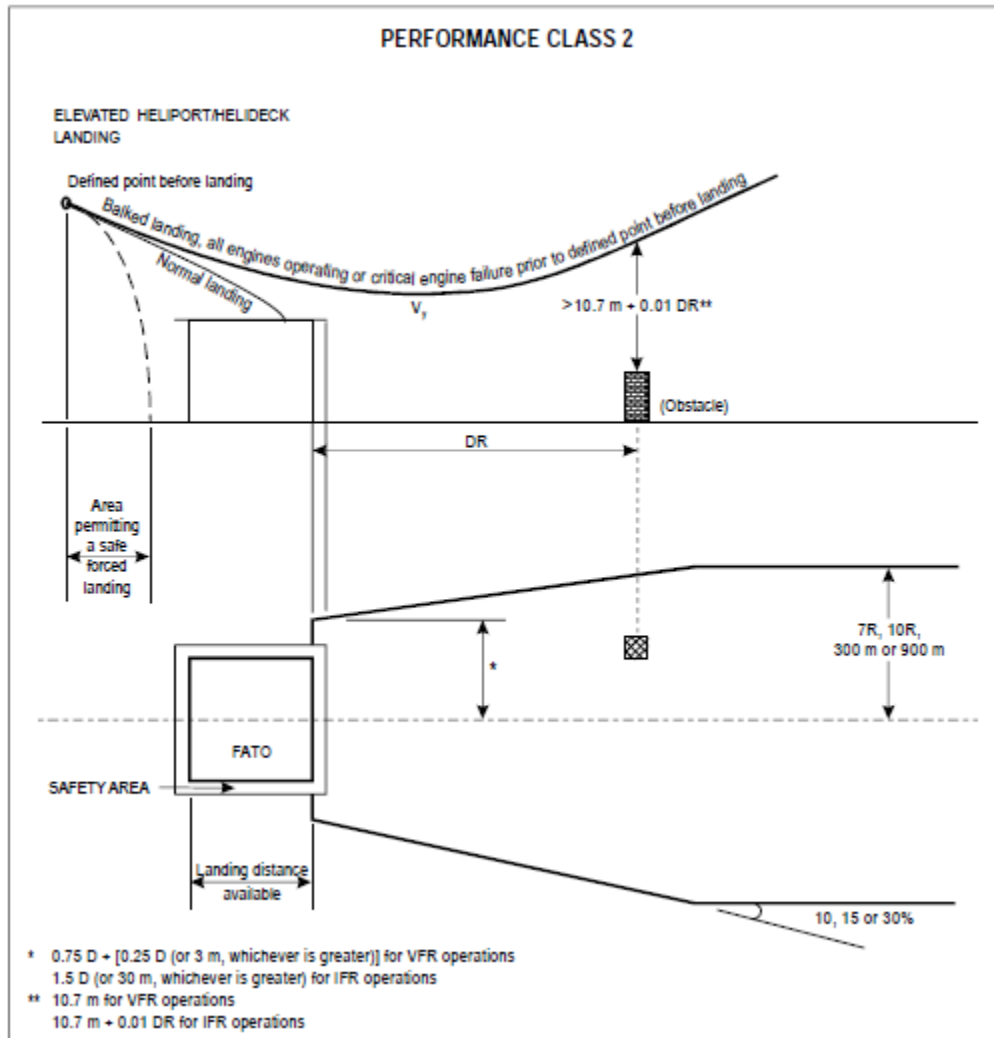

The Remainder of this page intentionally left blank

End of RCAR Part 17